

Tubolari per portoni

spessore mm 1,5 - Neri e Zincati

MT5 - 15/10=kg/ml 1,65

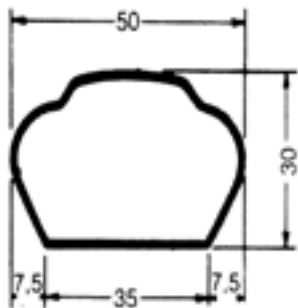

MT6 - 15/10=kg/ml 2,15

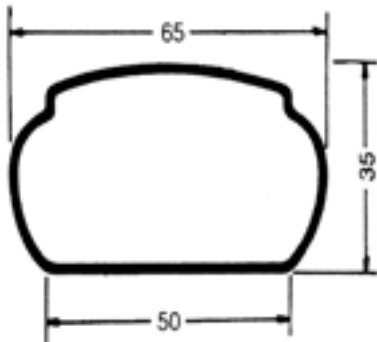

MT7 - 15/10=kg/ml 2,15

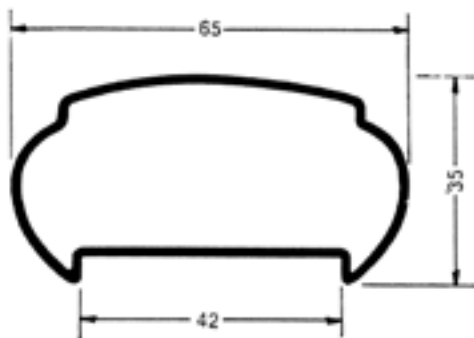

MT8 - 15/10=kg/ml 1,87

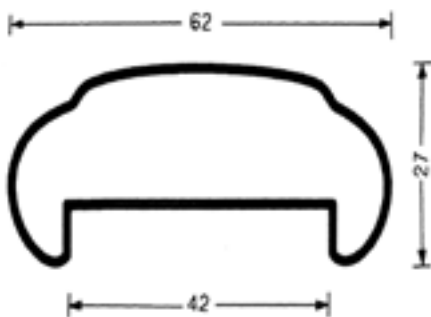

MT9 - 15/10=kg/ml 1,60

